

Scrap Shear MS-4000

Cutting Force	Blade length	Ejection height	Performance	Power	Weight
4000 KN	1400mm	400 - 500mm	5-7 t/h	74 kW	27 – 35t

Stationary versions

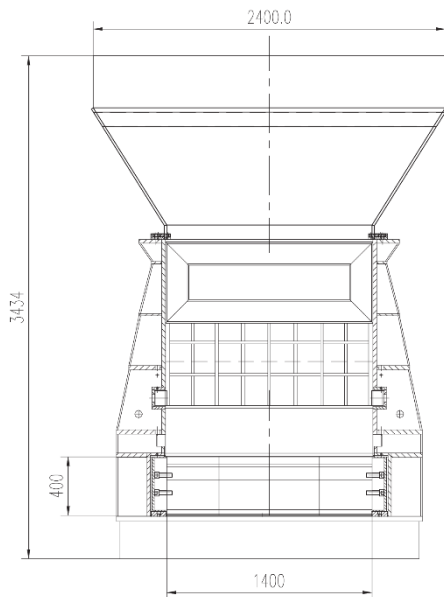

MS-4000e

Drive	electric
Ejection height	400mm / 500mm
Power	74 kW
Weight	27t

MS-4000d

Drive	diesel engine
Ejection height	400mm / 500mm
Power	125 HP
Weight	27,5t

Mobile versions

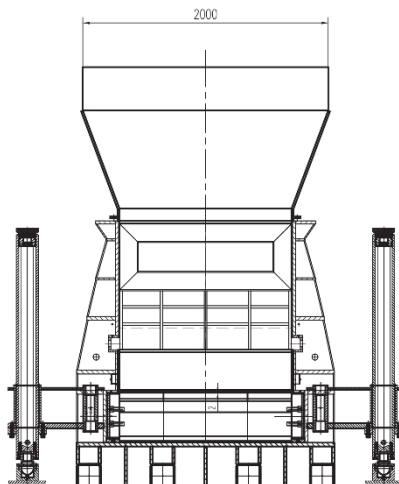

MS-4000me

Drive	electric
Ejection height	400mm / 500mm
Power	74 kW
Weight	34,8t

MS-4000md

Drive	diesel engine
Ejection height	400mm / 500mm
Power	125 HP
Weight	35t

For the electrically driven models 4000e and 4000me, a diesel generator can be selected as an additional option - this ensures flexible and cost-optimized operation

Scrap Shear MS-4000e – stationary version, electric, side view

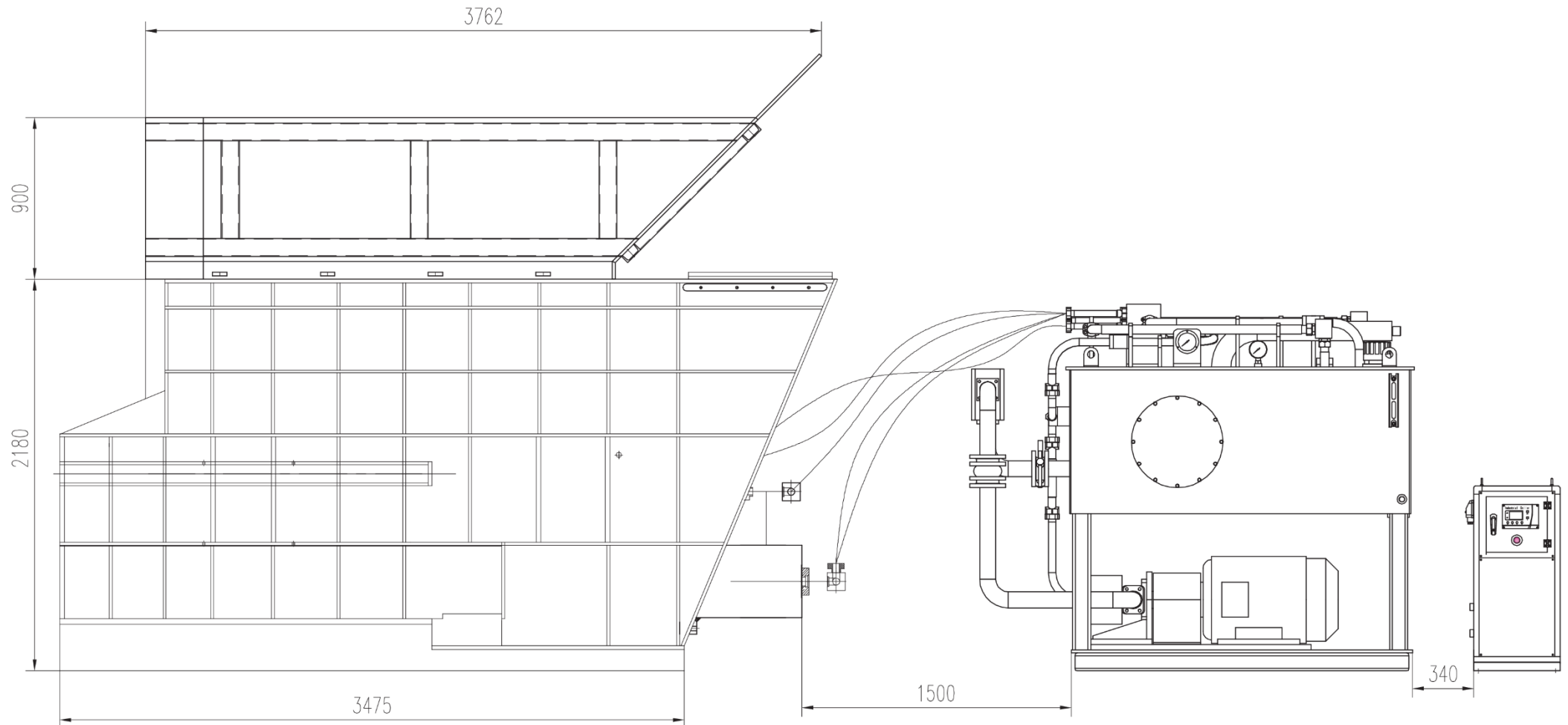

Scrap Shear MS-4000e – stationary version, electric, top view

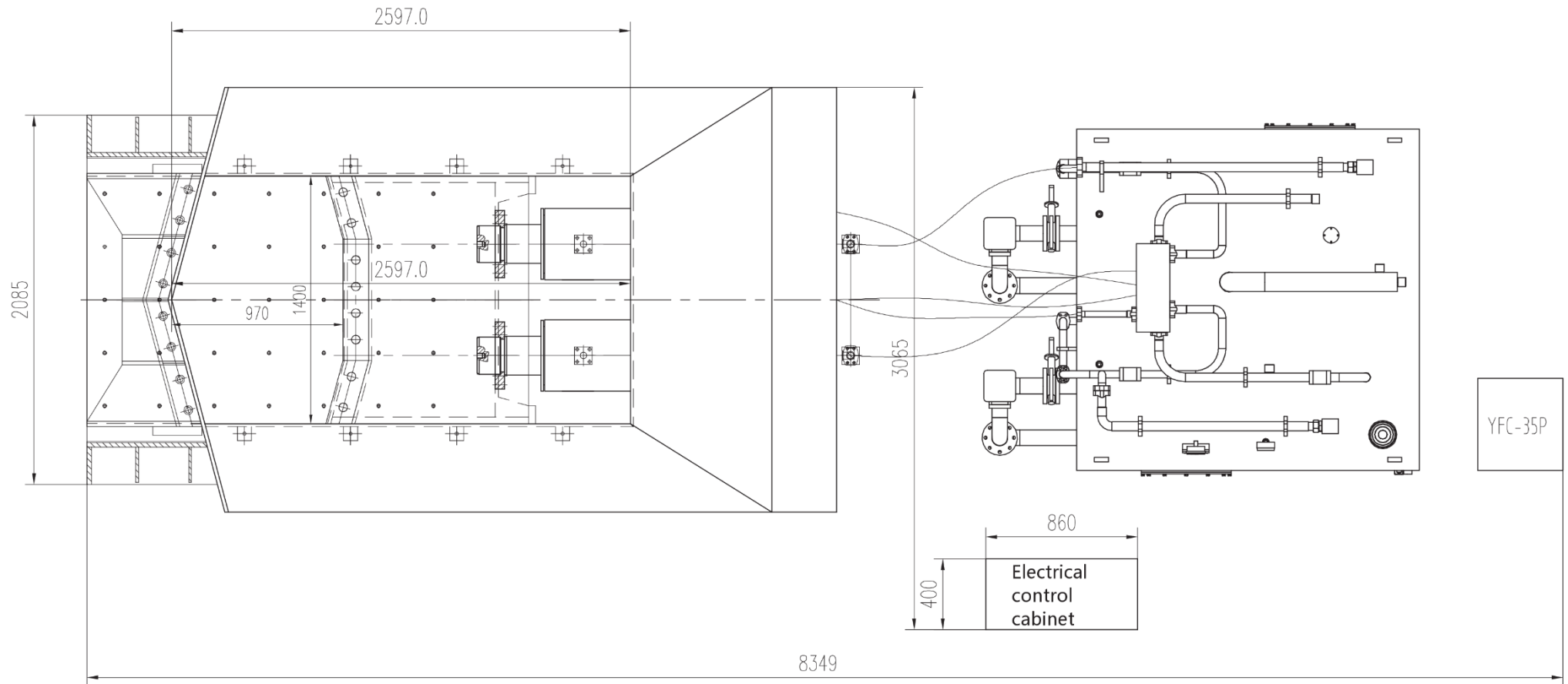

Scrap Shear MS-4000md – mobile version, diesel, side view

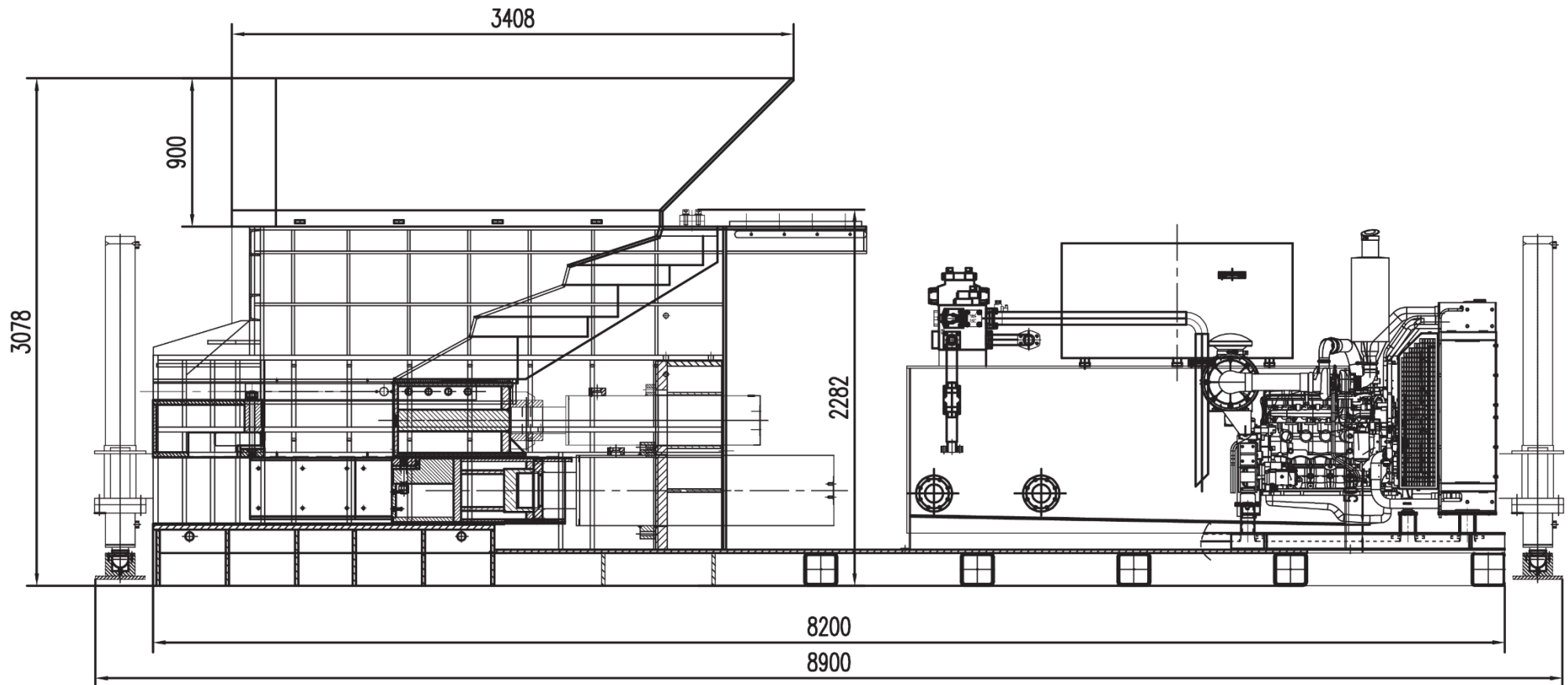

Scrap Shear MS-4000md – mobile version, diesel, top view

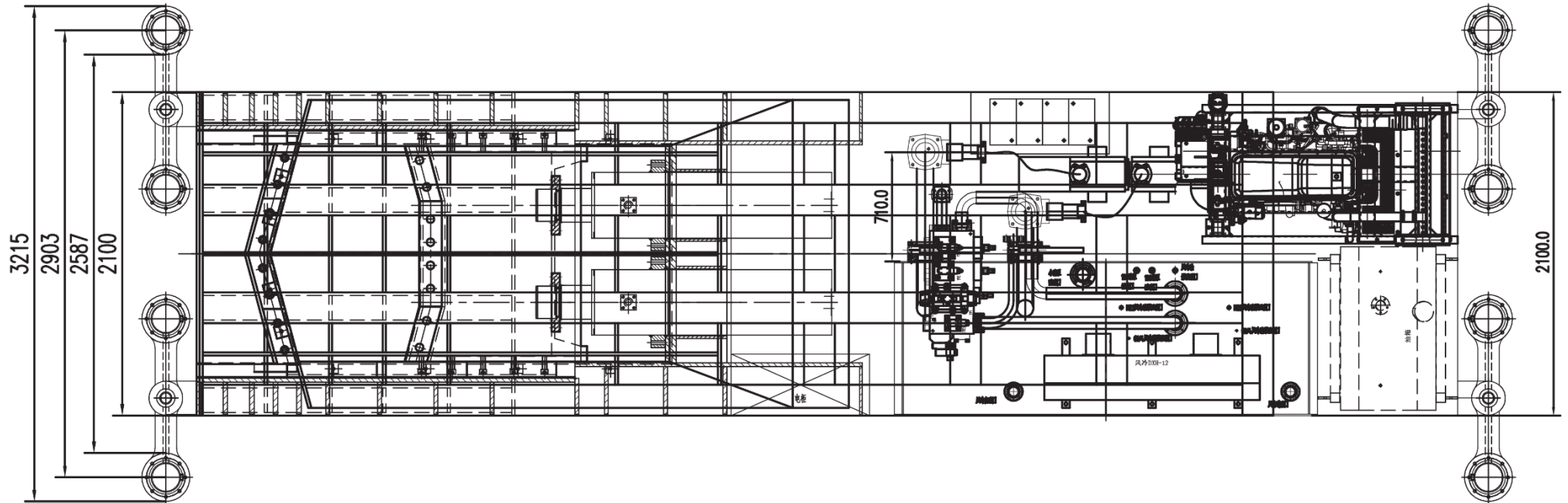

Scrap Shear MS-4000me – mobile version, electric, side view

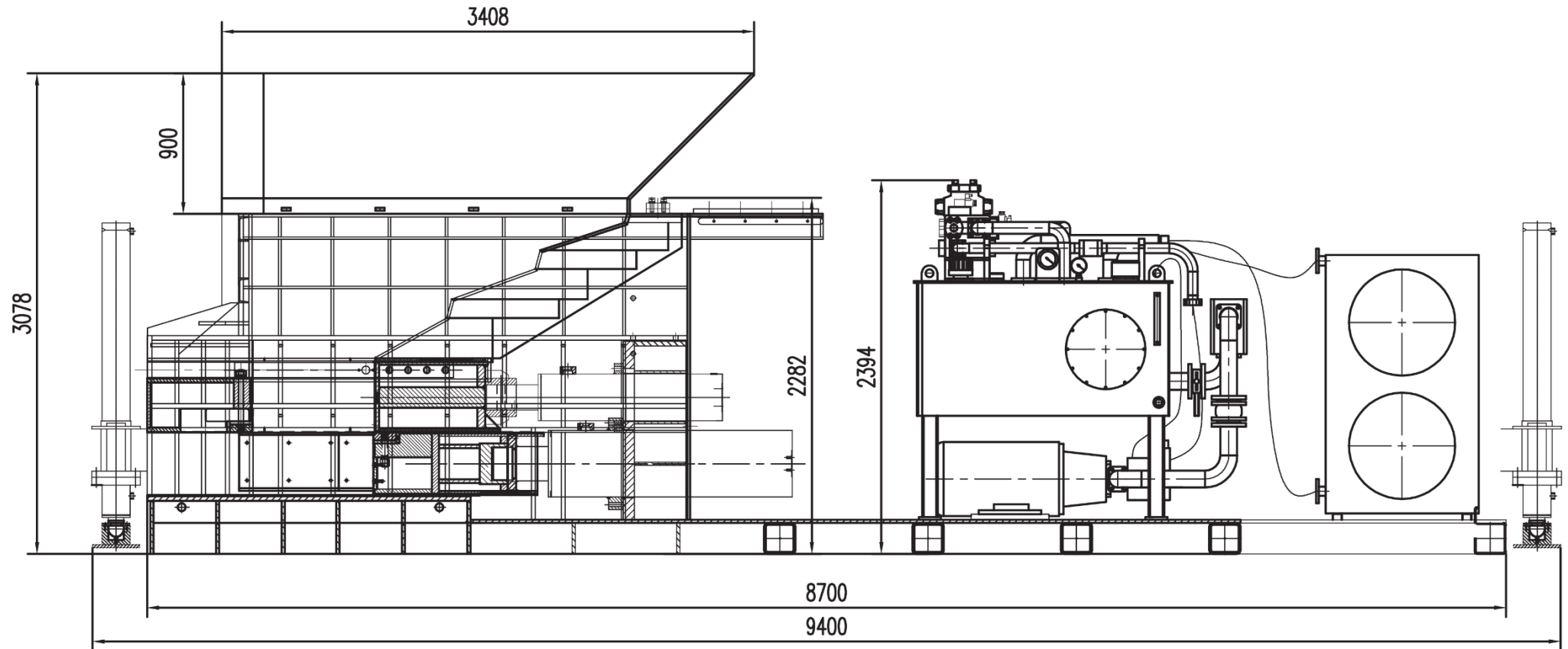

Scrap Shear MS-4000me – mobile version, electric, top view

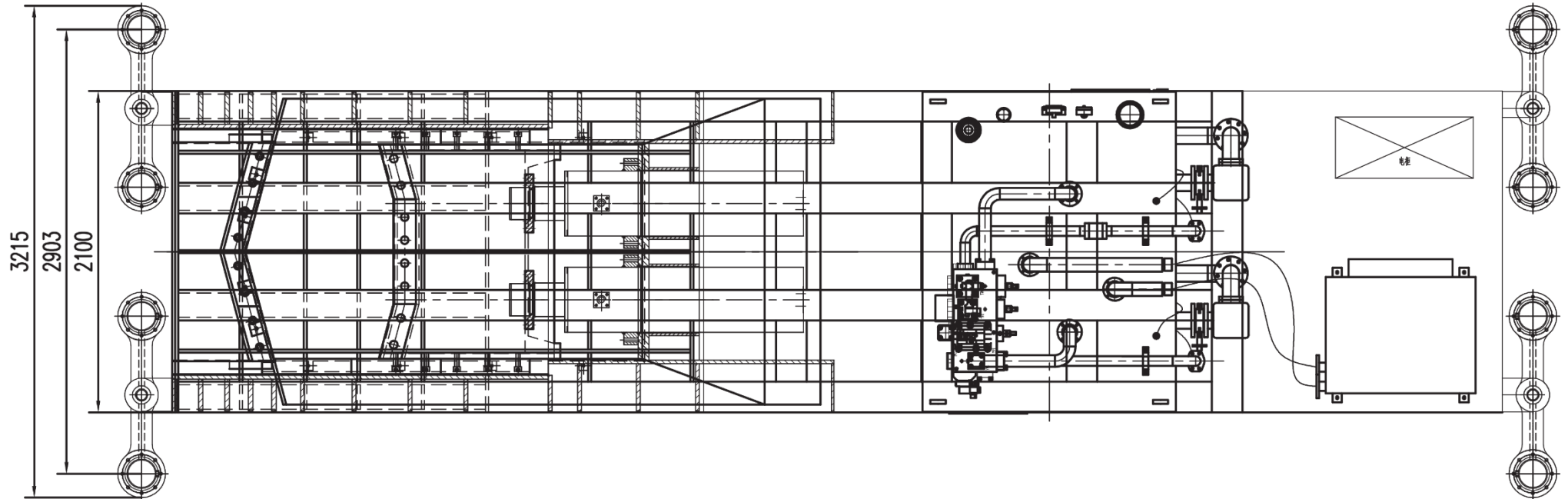

Advantages of the scrap shear

- The scrap shear enables economical scrap cutting due to the energy-saving automatic operation, saves costs and does not require a foundation.

Technical information

- The scrap shear can cut almost all types of scrap material. However, the machine is not recommended for cutting high carbon steel, such as axles, wire ropes, pig iron, spring steel plates, rails, alloy steel, hubs, etc - these hard materials will destroy the cutting blades.
- Production manufactured according to international standards. The specialized factories for the production of the scrap shears and their individual elements are certified according to ISO9001 and the CE certificate is available.
- Shear block, pressing device and the whole internal area of the scrap shear are made in HARDOX 450 wear resistance plates.
- Separate electrical cabinet for the different currents, components from Schneider Electronic and Siemens PLC.
- All contact surfaces are equipped with automatic lubrication to reduce equipment wear and increase equipment lifetime
- All high-pressure parts (piping, tank) are welded with forming, tested and acid treated to ensure the purity of the piping system



Function overview

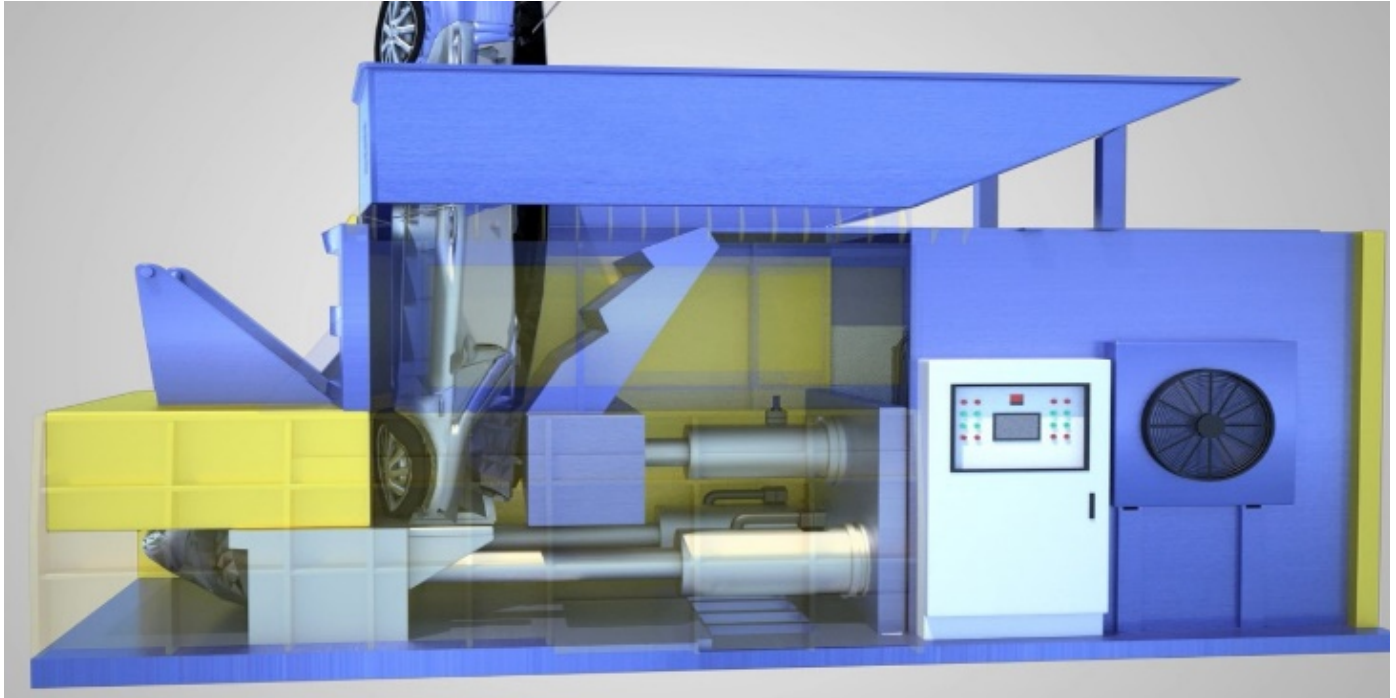

Scrap is fed into the loading area with the help of an excavator. Due to the horizontal filling area and the scrap's own weight, it falls down into the loading chamber and into the cutting area. The scrap is compacted at the front wall and cut by the horizontally moving tool carrier via the knives at the front wall. While the tool carrier carriage moves horizontally, the processed material is pressed out via the knives on the front wall of the container. When moving back to the rear position, the loaded scrap moves by its own weight into the interior of the shear.

Technical details

No.	MS4000 Container Shear Technical parameter					Remarks
1	Cutting CYL	Model	YG320/220-1020			2sets
		Nominal force	2010KN x2	Stroke	1020mm	
2	Press CYL	Model	YG250/160-450			1set
		Nominal force	1250KN x1	Stroke	750mm	
3	Chamber size(L×W×H)(mm)		3762*2400*900			
4	Feeding size (L×W×H)(mm)		2600*1400*1882			
5	Working system pressure		21.5MPA			
6	Blade length		1400MM			
7	Cutting size		400 - 500mm			
8	Cutting frequency		3.5 times/min (unloading)			
9	Motor	Model	Y250-M-4	Power	37KW	
		Speed	1470r/min	Quantity	2 sets	
10	Pump	Model	HY250Y-RP	Pressure	31.5Mpa	
		Outflow	250ml/r	Quantity	2sets	
11	Cooler	Air conditioning chiller				
12	Control	PLC Automatic+ touch screen +panel + remoter				